



Delta TR 300 / 400



Delta TR 300

The mobile belt elevator Delta enables:

- To feed presses, destemmers, sorting tables, maceration tanks... with **fresh grapes**.
- To feed presses with **macerated grapes**.
- To evacuate **stems and dried pomace**.

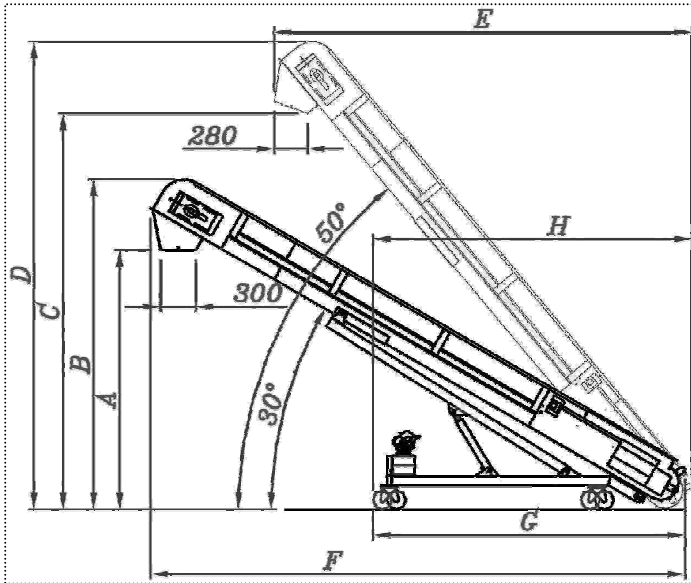

	A	B	C	D	E	F	G	H
2.5 m	1210	1810	1825	2435	2240	2780	1665	1730
3 m	1465	2070	2205	2820	2560	3210	1665	1730
3.5 m	1705	2305	2590	3200	2885	3650	2190	2250
4 m	1960	2555	2975	3585	3205	4080	2190	2250
4.5 m	2195	2800	3350	3965	3530	4520	2640	2695
5 m	2445	3050	3730	4345	3860	4950	2640	2695
5.5 m	2665	3265	4115	4725	4170	5400	3140	3200
6 m	2910	3515	4495	5110	4490	5830	3140	3200
6.5 m	3195	3795	4880	5495	4810	6245	3595	3650
7 m	3445	4045	5265	5880	5130	6680	3595	3650
7.5 m	3705	4305	5650	6265	5450	7110	3980	4150
8 m	3955	4555	6035	6645	5770	7540	3980	4150

Delta TR 300 and Delta TR 400 assets

- Trolley with hydraulic lever.
- Cleaning rubber below belt.
- Cleaning and discharge opening.

Robustness

- Exposed stainless steel framework of 304L – folded sheet thickness 20/10 – sand-blasted.
- Belt with curved brackets width: 300 mm / Height 60 mm or 400 mm / Height 80 mm, depending on material to be transferred.
- Double-folded stiff belt – in compliance with the FDA Food Approval – with stainless steel staples.
- PVC bearings – Waterproof stainless steel rolling.
- Stainless steel protecting carter of the engine.
- On/Off button with a heat-proof system of the engine + 10 m. of wire.

Adaptability

- Inclination of elevators is adjustable from 30° to 50° max. by means of hydraulic cylinders and manual pump.
- Stainless steel trolley with 4 DN 160 tilting wheels with brakes – polyurethane shrouding.

Easy cleaning

- Exposed stainless steel framework giving way to below belt.
- Cleaning rubber of below belt.
- Opening for the cleaning of driving tumbler.

Options

- Reception hopper under Delta E 2 destemmer.
- Reception hopper under tank door (height: 500 mm).
- Hopper for screw conveyor (minimum height: 450 mm.).
- Reception hopper at the end of belt or vibrating table.
- High capacity reception hopper of 1200 x 1000 mm.
- Dismounting of hoppers by means of a quick system of clippers.
- Motor equipped with a frequency variator.
- Directional gully with swivel length 1000 or 1500 mm.
- Integrated cleaning rail of return belt.
- Flexible hose outlet length 700 mm.

Distributed by :

Bucher Vaslin

Rue Gaston Bernier – BP 70028
F - 49290 Chalonnes sur Loire
Tél. +33 (0)2 41 74 50 50
Fax +33 (0)2 41 74 50 51
E-mail : commercial@buchervaslin.com

www.buchervaslin.com

Your success is our priority